



GROVE[®] **GMK4100-L**

100 T

-  100 t
-  60 m
-  10 - 17 m



All-Terrain Crane • AT-Kran
Grue Automotrice Routière

Grúa Todo Terreno Rapida • Gru Fuoristrada Veloci
Вездеходный подъемный кран

Manitowoc

www.manitowoccranes.com



MARTIN

100 T

Dimensions • Abmessungen • Encombrement • Dimensiones • Dimensioni • Размеры

11

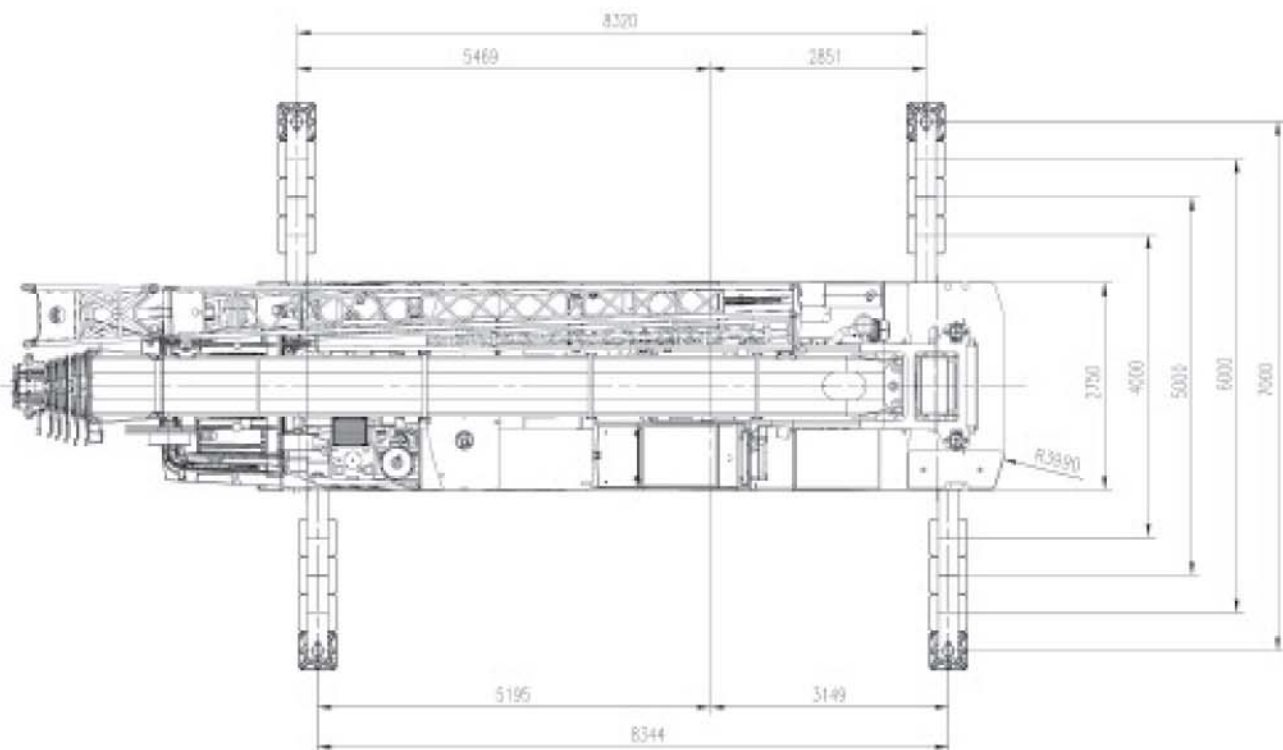
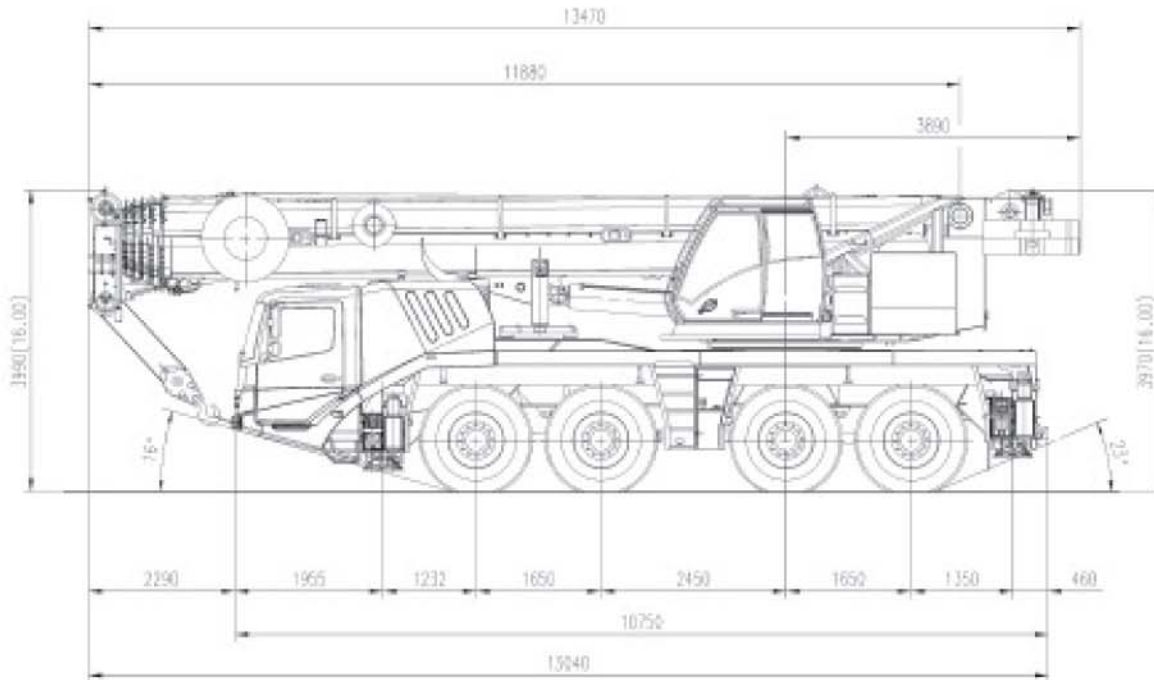

Ra = Radius all wheels steered
 Radius allrad gelenkt
 Rayon toutes les roues directrices
 Radio de giro con todas las ruedas giradas
 Raggio di curva con tutte le ruote sterzate
 Радиус поворота при управлении всеми колесами

GMK4100-L

GROVE



MARTIN

100 T

16



11,65-60,0 m



7,0 m



360°

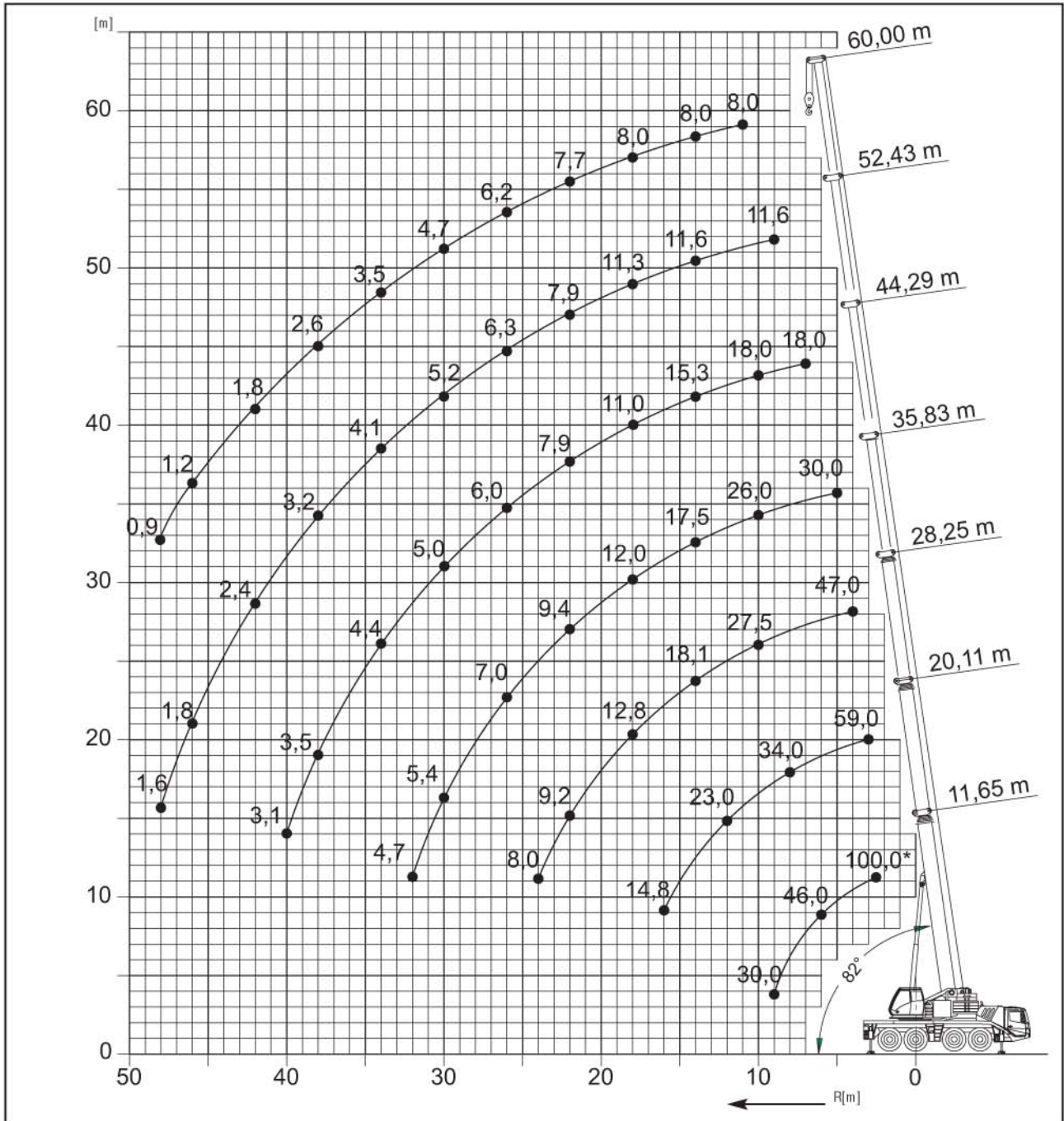

GMK4100-L



Hook block • Unterflasche • Crochet-moufle • Gancho • Ganci • Крюковой блок (t)

H (mm)

100 D	3100
63 E/D	3000
40 E/D	2900
20 E/D	2800
8 H/B	2350

GROVE.



MARTIN

100 T

17



11,65-60,0 m



7,0 m



360°



26,1 t



EN13000

m	11,65*	11,65	15,90	20,11	24,26	28,25	32,11	35,83	40,08	44,29	48,43	52,43	56,28	60,00
2,5	100,0													
3,0	69,0	69,5	63,5	59,0	56,0									
4,0	59,0	58,5	56,0	52,5	49,5	47,0								
5,0	52,0	50,0	49,5	47,0	44,5	41,5	37,5	30,0						
6,0	46,0	43,5	44,0	41,5	40,5	38,0	36,5	30,0	23,0					
7,0	41,0	38,0	38,5	37,5	36,5	35,0	33,5	30,0	23,0	18,0				
8,0	36,0	34,0	34,5	34,0	33,0	32,0	31,0	29,5	23,0	18,0	14,3			
9,0	30,0	30,0	31,0	31,0	30,0	29,5	28,5	28,0	22,5	18,0	14,3	11,6		
10,0			28,0	28,5	27,5	27,5	26,0	26,0	21,5	18,0	14,3	11,6	9,5	
11,0			25,5	25,5	25,5	25,5	24,0	24,0	20,5	17,7	14,3	11,6	9,5	8,0
12,0			22,5	23,0	22,5	23,0	21,5	21,5	19,1	17,0	14,3	11,6	9,5	8,0
13,0			19,7	20,0	19,8	20,5	19,7	19,3	17,9	16,2	14,2	11,6	9,5	8,0
14,0				17,7	18,3	18,1	18,6	17,5	16,4	15,3	14,0	11,6	9,5	8,0
15,0				16,4	16,5	16,2	16,8	15,9	14,9	14,4	13,3	11,5	9,5	8,0
16,0				14,8	14,8	14,8	15,2	14,6	13,6	13,1	12,6	11,3	9,5	8,0
18,0					12,2	12,8	12,5	12,0	12,4	11,0	10,8	10,6	9,5	8,0
20,0					10,8	10,8	10,5	10,4	10,5	9,3	9,2	9,2	9,0	8,0
22,0						9,2	8,9	9,4	8,9	7,9	7,8	7,9	8,0	7,7
24,0						8,0	8,2	8,1	7,6	6,6	7,1	6,9	7,1	7,1
26,0							7,4	7,0	6,5	6,0	6,6	6,3	6,4	6,2
28,0								6,5	6,1	5,6	6,0	5,6	5,7	5,4
30,0									5,4	4,9	5,0	5,2	5,1	4,7
32,0									4,7	4,2	4,6	4,6	4,4	4,1
34,0										3,9	4,4	4,1	3,9	3,5
36,0										3,2	4,0	3,8	3,4	3,0
38,0											3,5	3,4	3,2	2,9
40,0											3,1	3,0	2,8	2,6
42,0												2,7	2,4	2,2
44,0													2,1	1,8
46,0														1,5
48,0														1,2
50,0														0,9
52,0														1,0

* 0° over rear, nach hinten, en arrière, por la parte trasera, sul posteriore, Над задней частью



11,65-60,0 m



7,0 m



360°



21,7 t



EN13000

m	11,65	15,90	20,11	24,26	28,25	32,11	35,83	40,08	44,29	48,43	52,43	56,28	60,00	
2,5														
3,0	69,5	63,5	59,0	56,0										
4,0	58,0	56,0	52,5	49,5	47,0									
5,0	49,5	49,5	47,0	44,5	41,5	37,5	30,0							
6,0	43,0	43,5	41,5	40,5	38,0	36,5	30,0	23,0						
7,0	38,0	38,5	37,5	36,5	35,0	33,5	30,0	23,0	18,0					
8,0	34,0	34,5	34,0	33,0	32,0	31,0	29,5	23,0	18,0	14,3				
9,0	30,0	31,0	31,0	30,0	29,5	28,0	27,5	22,5	18,0	14,3	11,6			
10,0		27,5	28,0	26,5	26,0	24,5	24,0	21,5	18,0	14,3	11,6	9,5		
11,0		23,5	23,5	23,0	23,0	22,5	21,5	20,0	17,7	14,3	11,6	9,5	8,0	
12,0		20,5	20,5	21,0	20,5	20,5	19,1	17,9	17,0	14,3	11,6	9,5	8,0	
13,0		17,9	18,5	18,6	18,3	18,5	17,2	16,0	15,4	14,2	11,6	9,5	8,0	
14,0			16,4	16,4	16,5	16,7	15,5	14,6	13,9	13,6	11,6	9,5	8,0	
15,0			14,6	14,7	15,3	15,0	14,1	14,0	12,6	12,3	11,5	9,5	8,0	
16,0			13,1	13,4	13,8	13,5	12,8	13,1	11,4	11,2	11,1	9,5	8,0	
18,0				11,5	11,4	11,1	11,3	11,1	9,5	9,4	9,3	9,5	8,0	
20,0					9,6	9,5	9,5	9,2	8,0	8,3	8,1	8,2	8,0	
22,0						8,1	8,6	8,3	7,7	7,2	7,7	7,5	7,6	7,0
24,0						7,3	7,4	7,1	6,6	6,6	7,0	6,9	6,6	6,0
26,0							6,4	6,1	5,6	6,0	6,0	6,0	5,7	5,2
28,0								5,6	4,8	5,3	5,2	5,3	5,0	4,5
30,0									4,6	4,5	4,9	4,6	4,3	3,8
32,0									4,0	4,2	4,3	4,0	3,7	3,3
34,0										3,9	3,7	3,4	3,1	2,8
36,0										2,5	3,4	3,2	2,9	2,3
38,0											3,0	2,8	2,5	1,9
40,0												2,4	2,2	1,5
42,0													2,1	1,2
44,0														1,2
46,0														0,9
48,0														1,0

GMK4100-L



MARTIN

100 T

Working range • Arbeitsbereiche • Diagramme de levage • Gama de trabajo • Area di lavoro • Грузовысотные характеристики



11,65-60,0 m



0° - 40°
10/17/22 m



7,0 m



360°

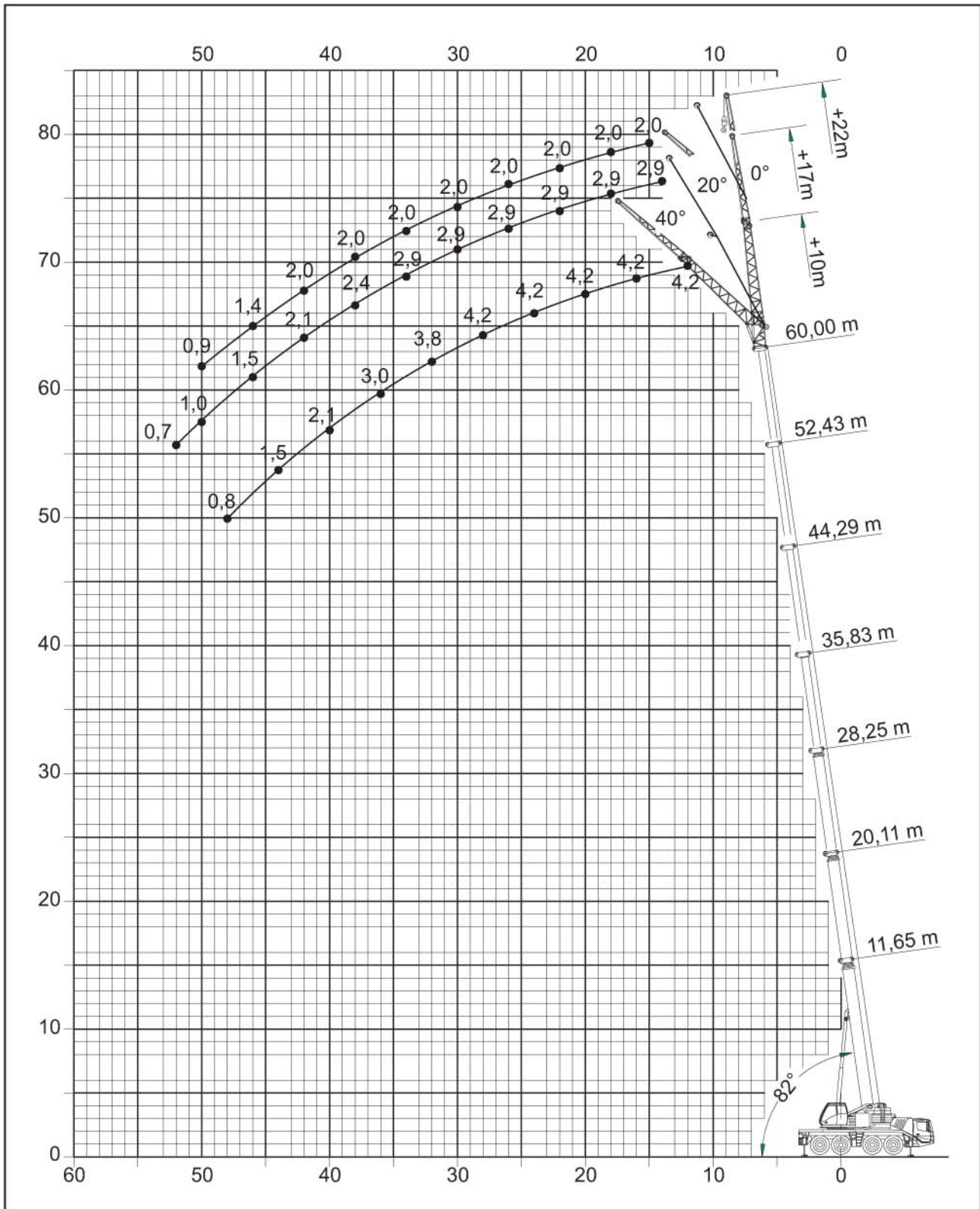

GMK4100-L

GROVE.